



***Puffer tanks AR-S (SPECIAL
FOR FALSE CEILINGS)
Primary cooling systems and
heat pumps***



***Installation instructions,
use and maintenance***

1. Product content

- Puffer storage tank
- Fittings on connections
- Transparent plastic bag with:
 - Energy efficiency sticker (Models: 20 - 1.500 Litres)
 - Three adhesive chocks (Models: 30 - 300 Litres)
 - Installation and use manual

2. General

Hot water tanks made of black steel with hydraulic connections to allow installation and combination in cooling systems and heat pumps.

All models feature CFC-free thermal insulation, which minimizes heat loss in the storage tank, therefore favouring energy savings and complying with current regulations in this area. They come in different configurations. The accumulators of the AR-S range are specially designed for installation in false ceilings. All models comply with the European Pressure Equipment Directive 2014/68/EU (Art. 4.3).

3. Application

The buffer storage tanks of the AR-A series are designed for exclusive use in closed cooling circuits and heat pumps. The tanks are not internally coated and should therefore not be installed in a secondary (open) circuit. They are not suitable for domestic hot water (DHW).

They are installed in those systems with thermal inertia, where the accumulation of energy is an essential factor for the efficient operation of the system, allowing to reduce the number of starts and stops of the groups when there are rapid temperature variations.

4. Arrival control

Check immediately that the equipment corresponds to the order and that all components are in perfect condition and that the correct operating instructions are enclosed. It is especially important to check the buffer tank for possible deformations that could affect its resistance. If defects or damage are found, contact the manufacturer immediately.

Check that the data on the sticker affixed to the buffer tank matches the purchase specification and is suitable for the installation. Before proceeding with the installation, make sure that the technical staff has an appropriate profile and training in the installation of this type of equipment. In any case, the local regulations in force for the operation of such equipment must be considered. Installation and operation must be carried out in accordance with good practice by professional installers and authorised technical personnel.

The manufacturer shall not assume any liability for damage caused by improper transportation, nor shall any damage caused by improper installation or misuse of the product be attributable to the manufacturer.

5. Normativa de montaje

In addition to national regulations and directives, the following installation regulations must be observed:

DIN 1988 Technical rules for domestic hot water installations

DIN 4708 Centralised water heating systems

DIN 4753 Storage tanks and heating systems for domestic hot water and primary heating systems

DIN 18380 Heating systems and centralised water heating systems

DIN 18381 Gas, water and drainage installations inside buildings

DIN EN 12828 Heating installations in the building. Design of DHW systems

EN 12897 Heat transfer to water - Specified for indirectly heated water heaters and pressure storage tanks (closed).

EN 12975 Solar thermal installation and its components.

6. Installation

They shall be installed in a weatherproof enclosure having the necessary access dimensions to facilitate inspection of the accumulator.

The installation in which the puffer tank is placed must provide for the installation of a safety system to limit the pressure and ensure that the pressure does not exceed the upper design limit of the buffer tank. The maximum working pressure value and pressure differentials must be taken into account when selecting a suitable safety relief valve.

The safety relief valve (DIN4753 Part 1 section 6.3.2) shall be installed by a T-connection at the upper connection V of the buffer storage tanks. It shall be connected directly to the storage tank, without any interposed valve, which would allow it to be shut off. An air vent shall be fitted at the other end of the T connection. The valve shall be accessible and mounted vertically.

Sizing of the safety relief valve and the exhaust duct

	Nominal capacity of the puffer tank	Maximum heating output	Minimum safety relief valve size	Minimum dimension of the input-output connection
	< 200 litres	75 kW	DN 15	1/2" - 3/4"
	200 - 1000 litres	150 kW	DN 20	3/4" - 1"
	1000 - 5000 litres	250 kW	DN 25	1" - 1 1/4"

If the heating capacity of the storage tank is higher than indicated for the nominal volumes given in the table, a suitably dimensioned safety relief valve must be used.



!!! The opening pressure of the safety relief valve must be at most equal to the working pressure of the tank!!!

The warning according to DIN 4753 part 1 section 6.3.4.2 must be read on the safety relief valve:



!!! During the heating phase, for safety reasons, water may escape from the exhaust duct!!!
!!! Keep the exhaust pipe open!!!

Safety valve evacuation pipeline: The evacuation of boiling water and steam must not endanger people. The discharge lines of 2 or more safety valves must lead freely and separately to a drainage point. The exhaust duct must be made with the same outlet section as the safety valve. It must not have more than 2 bends or be longer than 2 metres. If more than 2 bends or more than 2 metres in length are unavoidable, the cross-section of the exhaust duct must be increased accordingly. More than 3 bends and a duct length of more than 4 metres shall never be permissible. The end of the drainpipe must be clearly visible, protruding 20 to 40 mm above the drain pan or drain trap. The duct outlet must be within the ice protected area.

It is recommended to install a pressure reducer when the pressure in the network exceeds 4 bar.

Provide for the installation of a correctly dimensioned expansion vessel (EN12828). Ensure the correct functioning of the selected safety devices (safety valve, reducer, expansion vessel,) avoiding their interception by other elements.

Use a non-return valve or siphon at the cold water inlet with a length of 10 times the pipe diameter to avoid heat loss due to reverse circulation.

It is recommended to install air vents to prevent air accumulation.

The installation of automatic filling valves in closed primary heating circuits is not recommended, as it may lead to re-oxygenation in the system. In the case of combined systems, potential oxygen supply parts of the system must be isolated from the primary circuit or materials must be used to prevent oxygen supply.

It is obligatory to install a water meter in the primary closed heating circuits to check that there are no renewals above the values allowed by the standard.

Only original manufacturer's components may be used as spare parts.

This is an indicative layout. It is never a substitute for an expert's project.

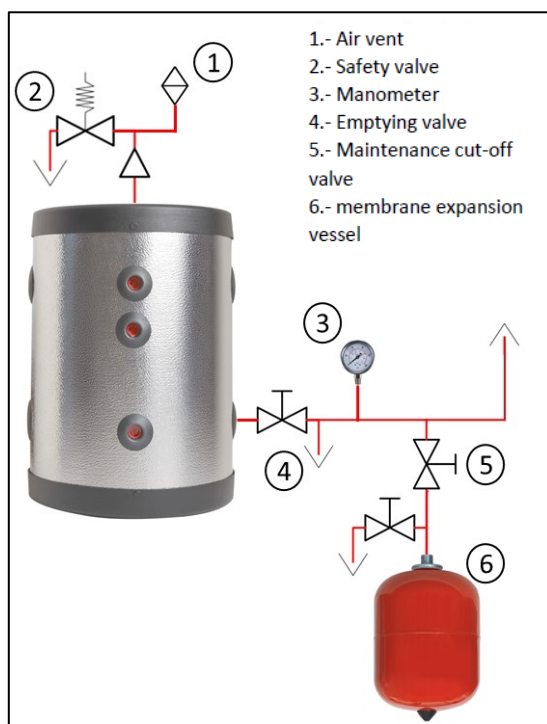

7. Filling

Make sure that the hoses and couplings of the system are watertight.

Check all connections of the accumulator for tightness and closure. All connections that are not to be used must be properly plugged.

Proceed with the flushing of the pipelines according to DIN 1988.

Fill the puffer tank and drain it.

Fill the heating circuit according to VDI 2035 standard, Purge and increase the operating pressure. Do not exceed the maximum operating pressure indicated on the label of the buffer tank.

Check the tightness of the connections at working pressure.

Verify the activation pressure of the safety valve and check its functionality.

Refill the circuits if necessary after purging and check for leaks and operation.



- ii The tanks contain hot water at high temperatures.!!
- ii Do not touch the hydraulic connections of accumulators at high temperatures.!!

8. Maintenance

Maintenance should only be carried out by authorized technical personnel.
Check the cleanliness of filters.
Purge the circuits and check them for leaks.
Check the safety valve's activation pressure and functionality.
Check expansion vessel pre-charge.
Check the working pressure values and pressure fluctuations.
Verify temperatures.

9. Declaration of Conformity

INDUSTRIAS IBAIONDO, S.A., with VAT number A48045199 and address at Plentzia bidea, nº3, 48100 Munguia (Vizcaya), declares that the models contained in this document have been designed and manufactured in accordance with good technical practice, in accordance with article 4.3 of European Directive 2014/68/EU on Pressure Equipment.

AR-S SPECIAL PUFFER TANKS FOR FALSE CEILINGS

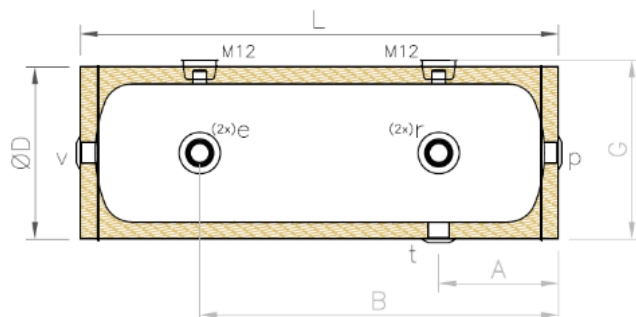

GENERAL CHARACTERISTICS AND DIMENSIONS

Model	20 AR-S	30 AR-S	40 AR-S
Model code	30002161	30003161	30004161
Nominal capacity (Litres)	20	30	40
Maximum working pressure (Bar)	6	6	6
Temperature (°C)	-10 / +100	-10 / +100	-10 / +100
Thermal insulation	PU rigid	PU rigid	PU rigid
Insulation thickness (mm)	20	20	20
External finish	embossed aluminium	embossed aluminium	embossed aluminium
Legs	No	No	No
ErP 	C	C	C
Weight (Kg)	7	10	12

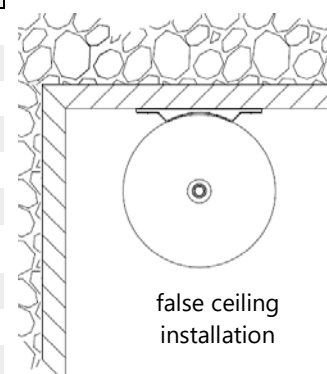

Connections			
e_r / e_c : lateral entrances	2 x 1" G.H	2 x 1" G.H	2 x 1" G.H
r_r / r_c : lateral exits	2 x 1" G.H	2 x 1" G.H	2 x 1" G.H
p	½" G.H.	½" G.H.	½" G.H.
v	½" G.H.	½" G.H.	½" G.H.
t: Auxiliary (purge)	½" G.H.	½" G.H.	½" G.H.

Dimensions (mm)			
ØD: Diameter ext.	250	250	250
L: Total length	700	1.000	1.230
A	175	175	175
B	520	820	1.050
G	270	270	270
B-A (Supports)	345	645	875

Accessories	References
Support kit	19011052
Purge	14500400

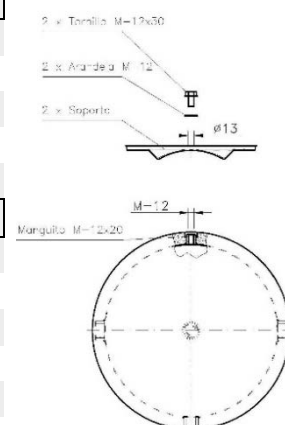

Note: If the tank is installed horizontally and at the highest point of the system, the venting set with code no. 14500400 must be fitted to the t-sleeve of the tank so that the tank can be vented. Fill with the tap open until no more air comes out. Once water comes out, close the valve and finish pressurising the installation. Both covers have a central hole (P - V) and a trim, leaving both sleeves accessible. They are supplied uncapped.

10. Warranty

All IBAIONDO Industries products will be replaced or repaired free of charge in case of manufacturing defects, during the warranty period stated in the offer or, failing that, in the current catalogues. The general warranty period is two years, except for those products specifically indicated with a longer period.

The warranty period starts from the date of sale of the product by our customer, with a maximum limit of 12 months, counting from the date of delivery note from IBAIONDO. For this purpose, the invoice or sales receipt must be provided, showing the identification data of the product claimed (description and serial number). In case the customer does not provide the invoice with the above-mentioned requirements, the period shall start to run from the date of delivery by IBAIONDO.

The warranty does not apply if the defect is due to misuse of the product, non-prescribed use, improper handling, if the maximum pressure and/or temperature values have been exceeded or, in general, if any of the instructions for commissioning, use or maintenance, included in the documentation provided, have not been followed.

IBAIONDO is not responsible for direct or indirect damages, caused by breakdown or defect of its products, and any other claim that could derive from them, unless the law provides it with obligatory character.

If the instructions have been followed, IBAIONDO will either rectify the defect or deliver new products free of charge. It shall also be entitled to pay the buyer the amount corresponding to the value of the defective or missing products. Defective products shall be returned, at the request of IBAIONDO, before the delivery of the new product is verified.

11. Example of installation

